

<b>881740</b> <b>881741 REV</b>	<p><b>COMPLETE SERVICE BASE ENGINE</b> - Gen VI Engine with Roller Hydraulic Camshaft, One Piece Rear Seal and 4 Bolt Mains. Replaces Mark IV, Gen V &amp; Gen VI Big Block V-8's. Includes: Harmonic Balancer, Oil Pan, and Valve Covers. Does NOT include circulating water pump, intake, or flywheel.</p> <p>- Requires Electric Fuel Pump.</p> <p>90 Day Limited Warranty</p>
Additional Cost for Opposite Rotation	
<b>882740</b> <b>882751 REV</b>	<p><b>PARPAC</b> - Partial Engine Package  <i>Includes:</i> Complete Service Base Engine, Carburetor, Electric Fuel Pump Kit, Fuel Lines, Fuel/Water Separator, Electronic Distributor, High Performance Coil, Ignition Wire Set.</p> <p>One Year Limited Warranty</p>
Additional Cost for Opposite Rotation	
<b>E454S-MR2</b>	<p><b>ENPAC</b> - Complete Inboard/Outboard Engine Designed to Replace <u>Most</u> Merc Models 1986 &amp; Later - Includes: Parpac plus, Merc-Style Center Rise Manifolds with 4" Risers, Throttle Linkage, Alternator, Engine Wiring Harness, High Torque Bottom Mount Starter, Weather Cover, Flame Arrestor, Corrosion Resistant Plastisol Oil Pan, Seawater Pump, Sender Package, EZ Oil Drain, Superior Corrosion Resistant Urethane Paint.</p> <p>oOne Year Limited Warranty</p>
<b>S454S</b> <b>S454SR</b>	<p><b>SPORTPAC</b> - Complete Inboard Engine Available as Bobtail or with ZF or Velvet Drive Transmission - Includes: Enpac plus, Dual Alternator Belt Drive, 50 Amp Circuit Breaker, Heavy Duty Engine/Gear Cooler, Fuel/Water Separator, Top Mount Starter, Dual Remote Oil System, Reversible Dipstick &amp; Tube w/Oil Drain Fitting, Superior Corrosion Resistant Urethane Paint.</p> <p>One Year Limited Warranty</p>
Also Available As Opposite Rotation at Additional Cost	

**Available EnPac and SportPac Engine Options Include**  
**Alarm System   Fresh Water Cooling System**  
 (Front Mounted on Enpacs & Sportpacs / Rear Mounted on Sportpacs Only)  
**Additional EnPac Engine Options**  
**Power Steering**

SPECIFICATIONS	STANDARD
DISPLACEMENT (LITER/CID)	7.4L / 454
CYLINDERS	V-8
BORE & STROKE (INCHES)	4.25 X 4.00
COMPRESSION RATIO	8.4:1
FUEL SYSTEM	4 BBL HOLLEY
IGNITION	DELCO ELECTRONIC
FULL THROTTLE OPERATION (CARBURETED)	4000 - 4400
ROTATION (FLYWHEEL) ( <i>Opposite Rotation Available on Sportpac Only</i> )	CCW/CW
TRANSMISSION - SPORTPAC ONLY	ZF or BW
TOTAL WEIGHT - U.S. LBS. - ENPAC	870
TOTAL WEIGHT - U.S. LBS. - SPORTPAC W/DIRECT DRIVE	980

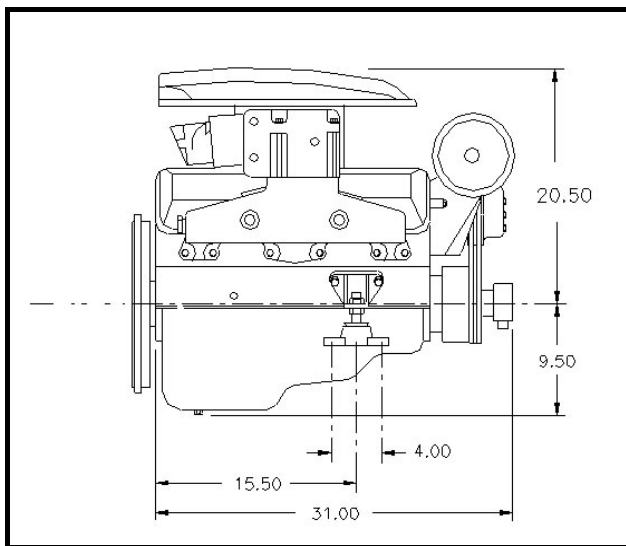

Enpac - Carbureted, FM Fresh Water Cooling

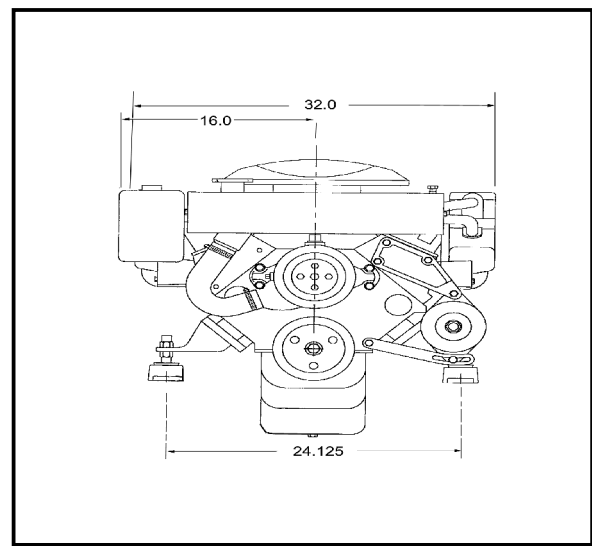

SportPac Carbureted